

Monorail Hanger Options

Summit Model #SM-MRH

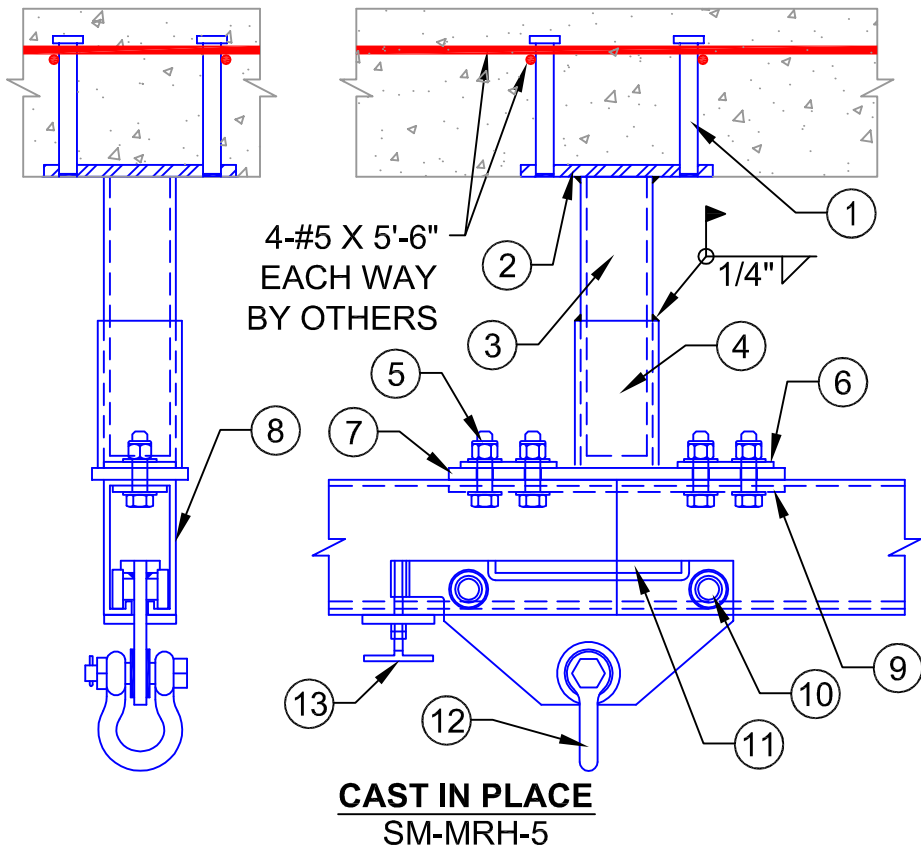

- ① (4) 3/4" Ø x 5-7/16" LG. STUDS
- ② 8" X 8" X 1/2" BASE PLATE SET FLUSH WITH CONCRETE SLAB
- ③ 3" HSS TUBE FOR VERTICAL ADJUSTMENT
- ④ 3-1/2" HSS TUBE
- ⑤ (4) BOLTS, LOCK WASHERS, & NYLON LOCKING HEX NUTS
- ⑥ 3" X 4" X 1/4" PLATE TO COVER SLOTTED HOLES
- ⑦ 14" X 4" X 1/2" SPLICE PLATE
- ⑧ ALUMINUM TRACK MONORAIL
- ⑨ 14" X 2-1/4" X 1/4" SPLICE PLATE
- ⑩ STAINLESS STEEL BEARING ROLLERS
- ⑪ SAFETY STOP
- ⑫ SUSPENSION SHACKLE
- ⑬ ADJUSTABLE TROLLEY BRAKE

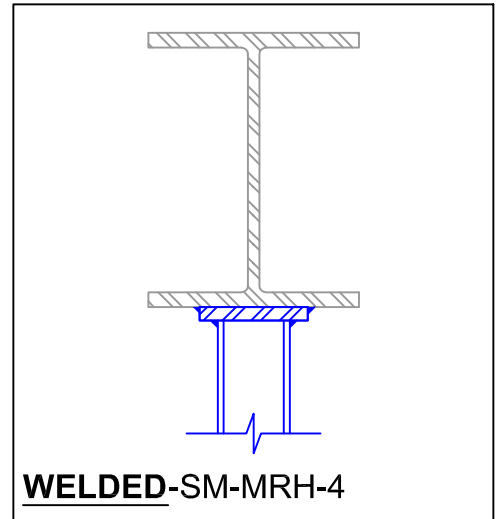

(4) 304 B8 SS HEAVY HEX NUT, SS LOCK WASHER, & GALV. FLAT WASHER

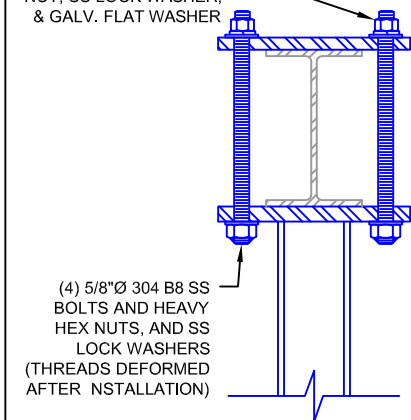

WRAP AROUND-SM-MRH-1

